

Grade 5 Science and Technology/Engineering

SESSION 1

DIRECTIONS

This session contains nine multiple-choice questions and one open-response question. Mark your answers to these questions in the spaces provided in your Student Answer Booklet.

- 1 During science class, students combined 1 kg of iron filings with 1 kg of sand to create a mixture. Which of the following methods would be **best** for separating the iron filings from the sand?
- A. Stir the mixture into hot water to dissolve the sand.
 - B. Strain the mixture through a paper filter to collect the sand.
 - C. Drag a magnet through the mixture to attract the iron filings.
 - D. Shake the mixture to cause the iron filings to settle to the bottom.

2 Which of the following sets of pictures shows the phases of the Moon in the order they would be observed?

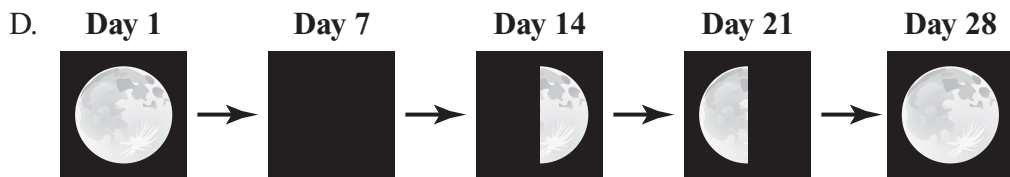
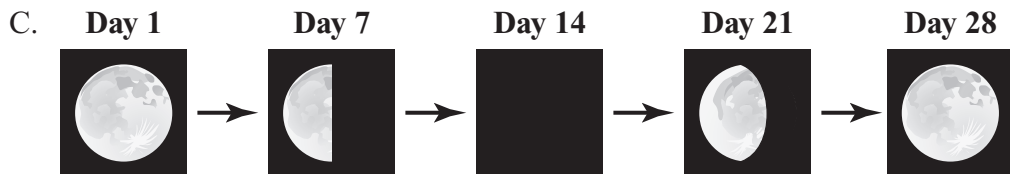
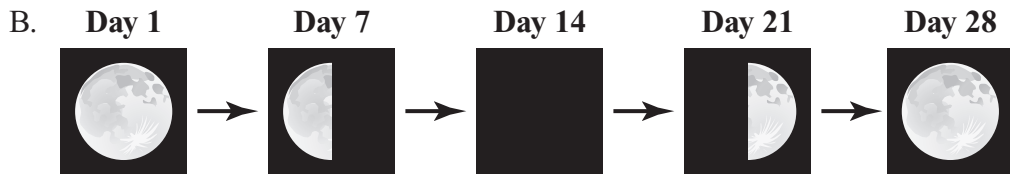
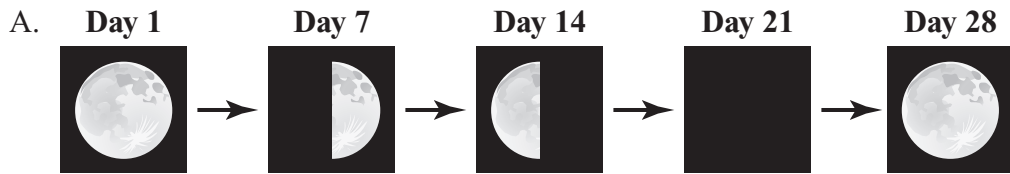

- 3 Which of the following groups of materials would **most likely** be used to build an electromagnet?
- A. bare wire, plastic rod, battery
 - B. bare wire, iron rod, light bulb
 - C. insulated wire, iron rod, battery
 - D. insulated wire, plastic rod, light bulb
- 4 Which of the following is an example of a form of energy?
- A. the air in a sealed jar
 - B. the wire in a metal hanger
 - C. the water in a small puddle
 - D. the sound in a loud classroom

- 5 A bird has just hatched from an egg. Which of the following stages **most likely** comes next in the life cycle of the bird?
- A. birth
 - B. death
 - C. growth
 - D. reproduction

- 6 Which of the following **best** describes a mineral?
- A. a solid natural material with a crystal structure
 - B. a material that was once living but has decayed
 - C. a liquid chemical used to make soil more fertile
 - D. a nutrient produced by plants that other organisms need

- 7 The pictures below show four objects that a student placed outside in the sunlight.



Aluminum foil



Clear glass



Black towel

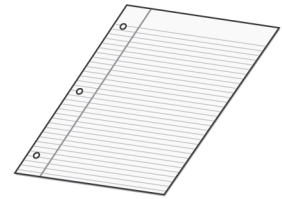

White paper

Which object should absorb the **greatest** amount of light?

- A. aluminum foil
- B. black towel
- C. clear glass
- D. white paper

8 While hiking last year, Mike saw a large boulder next to a mountain trail. The boulder had no cracks.

While hiking on the trail this year, he saw two large cracks in the boulder. Which of the following **most likely** caused these cracks to form?

- A. shaking from high winds
- B. pressure from flowing water
- C. erosion due to falling rain and snow
- D. weathering due to freezing and thawing

9 Which of the following shows two objects that are **both** conductors of electricity?

A.

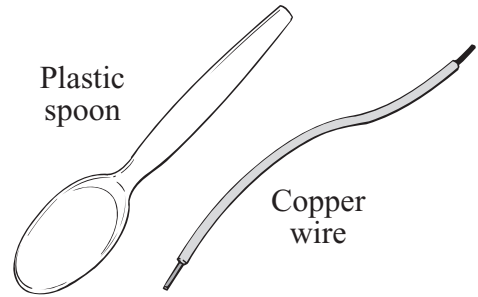

B.

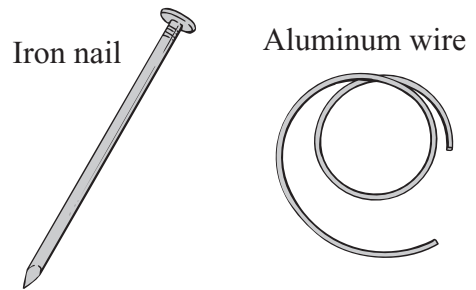

C.

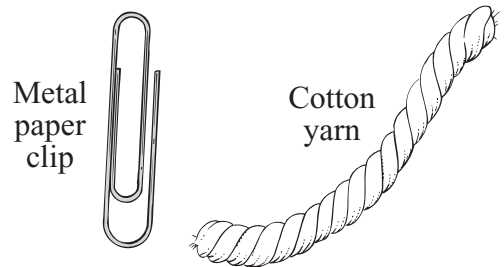

D.

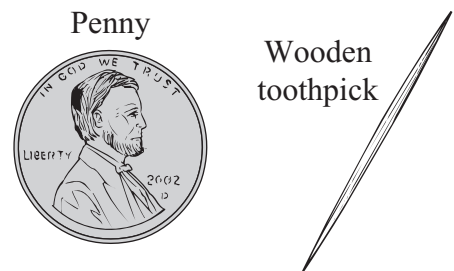

Question 10 is an open-response question.

- **BE SURE TO ANSWER AND LABEL ALL PARTS OF THE QUESTION.**
- **Show all your work (diagrams, tables, or computations) in your Student Answer Booklet.**
- **If you do the work in your head, explain in writing how you did the work.**

Write your answer to question 10 in the space provided in your Student Answer Booklet.

- 10** A prairie ecosystem includes many different organisms, such as grasses, coyotes, trees, mushrooms, snakes, and mice, as shown in the picture below. The energy needed by all the organisms in the ecosystem comes from one primary source.

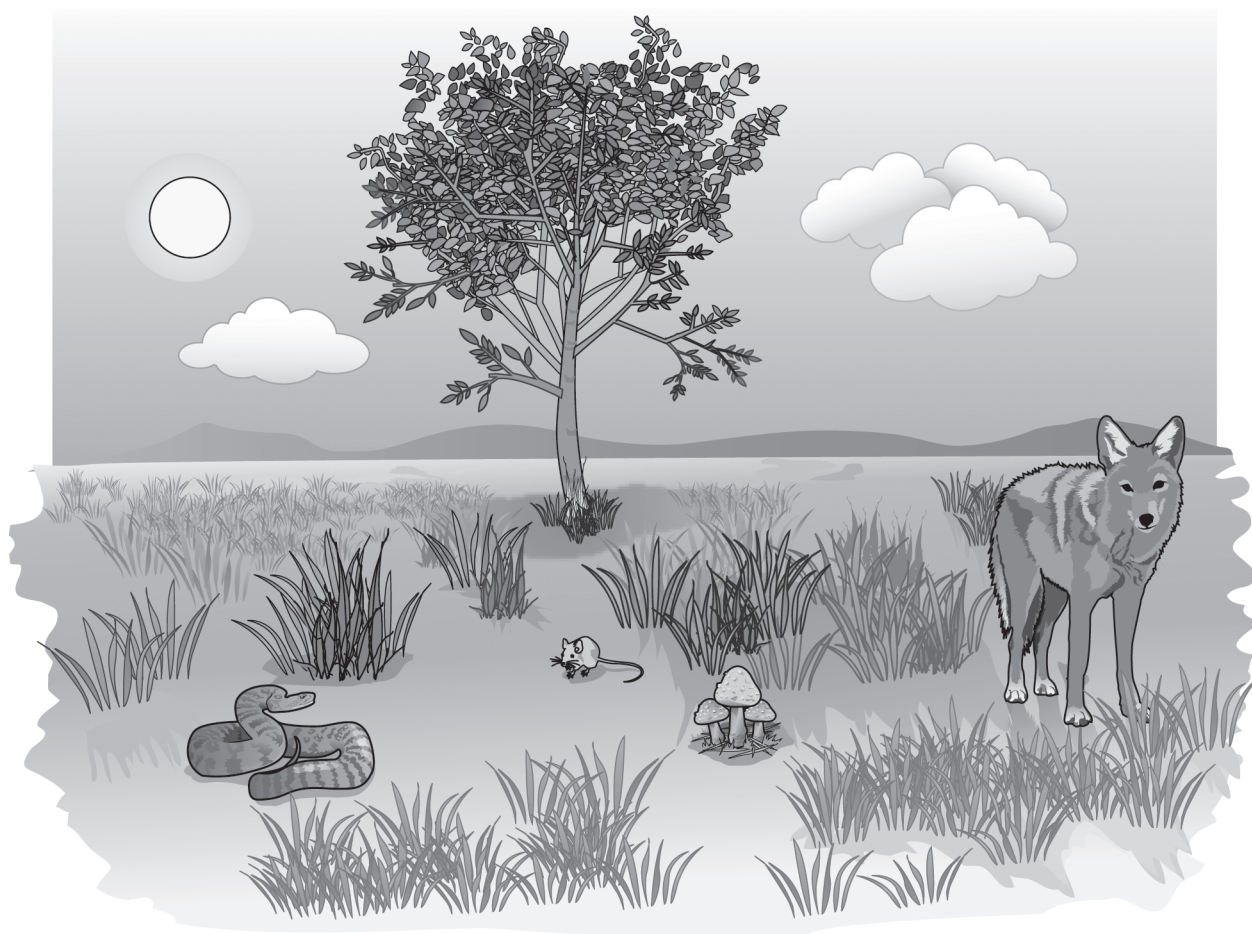

- Identify the primary source of energy in the prairie ecosystem.
- Identify one producer, one consumer, and one decomposer shown in the picture of the prairie ecosystem.
- Explain how the energy from the primary source you identified in part (a) moves through the prairie ecosystem. Be sure to include producers, consumers, and decomposers in your answer.

Grade 5 Science and Technology/Engineering

SESSION 2

DIRECTIONS

This session contains ten multiple-choice questions and one open-response question. Mark your answers to these questions in the spaces provided in your Student Answer Booklet.

- 11 Manuel is building a model to show how water from melting glaciers moves through the ocean. He puts clay, water, and ice cubes into a plastic bin. He places a heat lamp next to the bin. His model is shown in the diagram below.

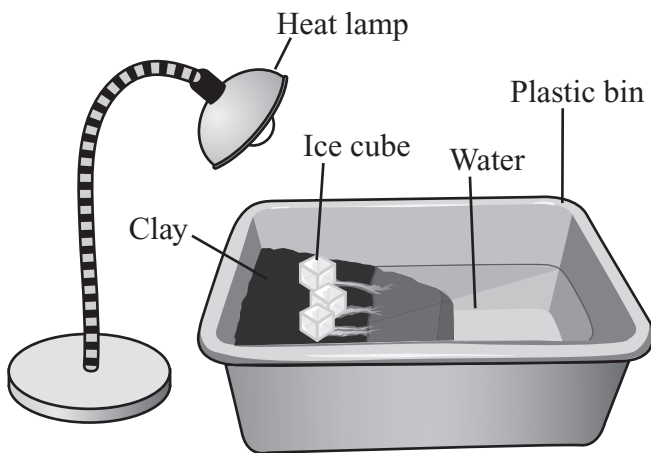

Which of the following would **most likely** help Manuel show how water from melting glaciers moves in his model?

- A. using colored water to represent the water in the ocean
- B. using colored water to make the ice cubes that represent the glaciers
- C. using different colors of clay to represent dry land and the bottom of the ocean
- D. using different colors of light to represent sunlight shining on the glaciers and dry land

- 12 A student freezes some orange juice. Which of the following statements **best** describes how the orange juice is different after it is frozen?

- A. It is a liquid.
- B. It weighs more.
- C. It stays in one shape.
- D. It takes up less space.

- 13 The picture below shows a farmer plowing a field.

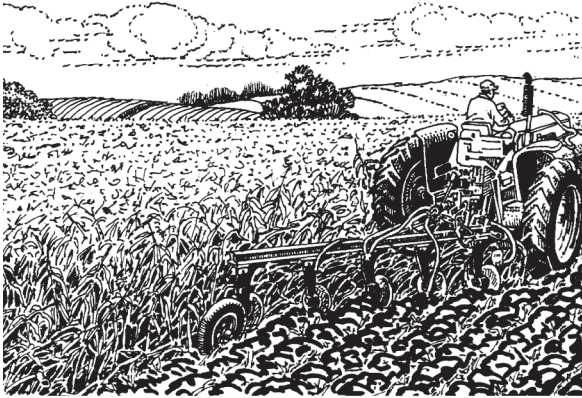

The farmer is plowing dead plants into the farmland soil. How does this improve the soil?

- A. The dead plants add nutrients to the soil.
- B. The dead plants bring oxygen to the soil.
- C. The dead plants absorb toxins from the soil.
- D. The dead plants reduce the carbon dioxide in the soil.

- 14 The arrows on the map below show the migration cycle of penguins that live near the southern tip of South America. The penguins complete this migration cycle once each year.

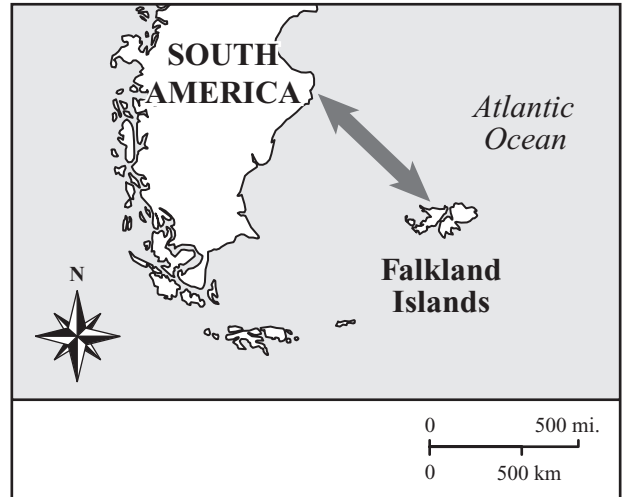

The migration of these penguins is in response to which of the following environmental conditions?

- A. change in temperature
- B. long period of drought
- C. decrease in ocean level
- D. increase in earthquakes

15 Which of the following data would be **most** useful for describing the climate of a specific area?

- A. average weekly wind speeds for 1 month
- B. daily relative humidity levels for 18 months
- C. total annual precipitation amounts for 2 years
- D. average high and low monthly temperatures for 20 years

16 The map below shows the location of South Carolina.



South Carolina is humid during the summer months. Which of the following is the **most likely** cause of the humid conditions?

- A. runoff from inland mountains
- B. flooding from rivers and streams
- C. groundwater bubbling to the surface
- D. evaporation from the surface of the ocean

- 17 One type of animal hatches from an egg, breathes through gills when it is young, and mainly lives on land as an adult. Into which group is this animal classified?
- A. amphibians
 - B. birds
 - C. mammals
 - D. reptiles
- 18 During which stage of its life cycle does a butterfly spend the **most** time eating plant leaves?
- A. adult
 - B. egg
 - C. larva
 - D. pupa

- 19 The Mohs scale for minerals is shown below.

Mohs Scale

softest	1	talc
	2	gypsum
	3	calcite
	4	fluorite
	5	apatite
	6	feldspar
	7	quartz
	8	topaz
	9	corundum
hardest	10	diamond

An unidentified mineral scratches fluorite but not quartz. According to the Mohs scale, what could be the unidentified mineral?

- A. apatite
- B. calcite
- C. diamond
- D. topaz

- 20 An area received six inches of snow during the winter. Before the snow can continue through the water cycle as ground water or runoff, it must first

- A. condense.
- B. evaporate.
- C. freeze.
- D. melt.

Question 21 is an open-response question.

- **BE SURE TO ANSWER AND LABEL ALL PARTS OF THE QUESTION.**
- **Show all your work (diagrams, tables, or computations) in your Student Answer Booklet.**
- **If you do the work in your head, explain in writing how you did the work.**

Write your answer to question 21 in the space provided in your Student Answer Booklet.

- 21 The students in a class want to build the type of seesaw shown below. The students can make the seesaw out of any material, but they know some materials have properties that make them a better choice to use for the seesaw than other materials.

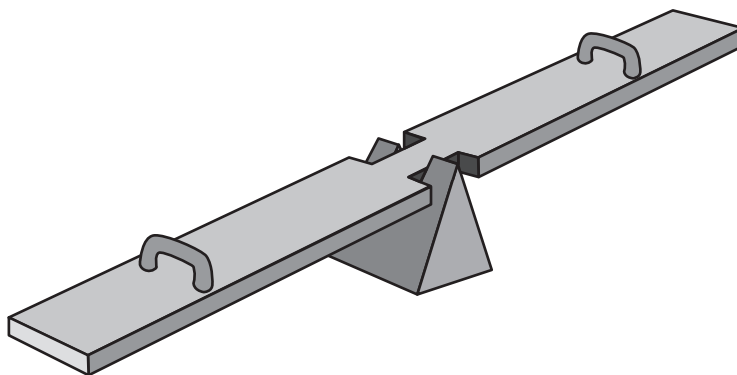

- Identify **one** material that would be a good choice for the students to use to build the seesaw.
- Describe **two** properties of the material you identified in part (a) that make it a good choice to use to build the seesaw.
- Describe **one** design feature that the students should consider before building the seesaw. Explain your answer.